

AWL SELECTION

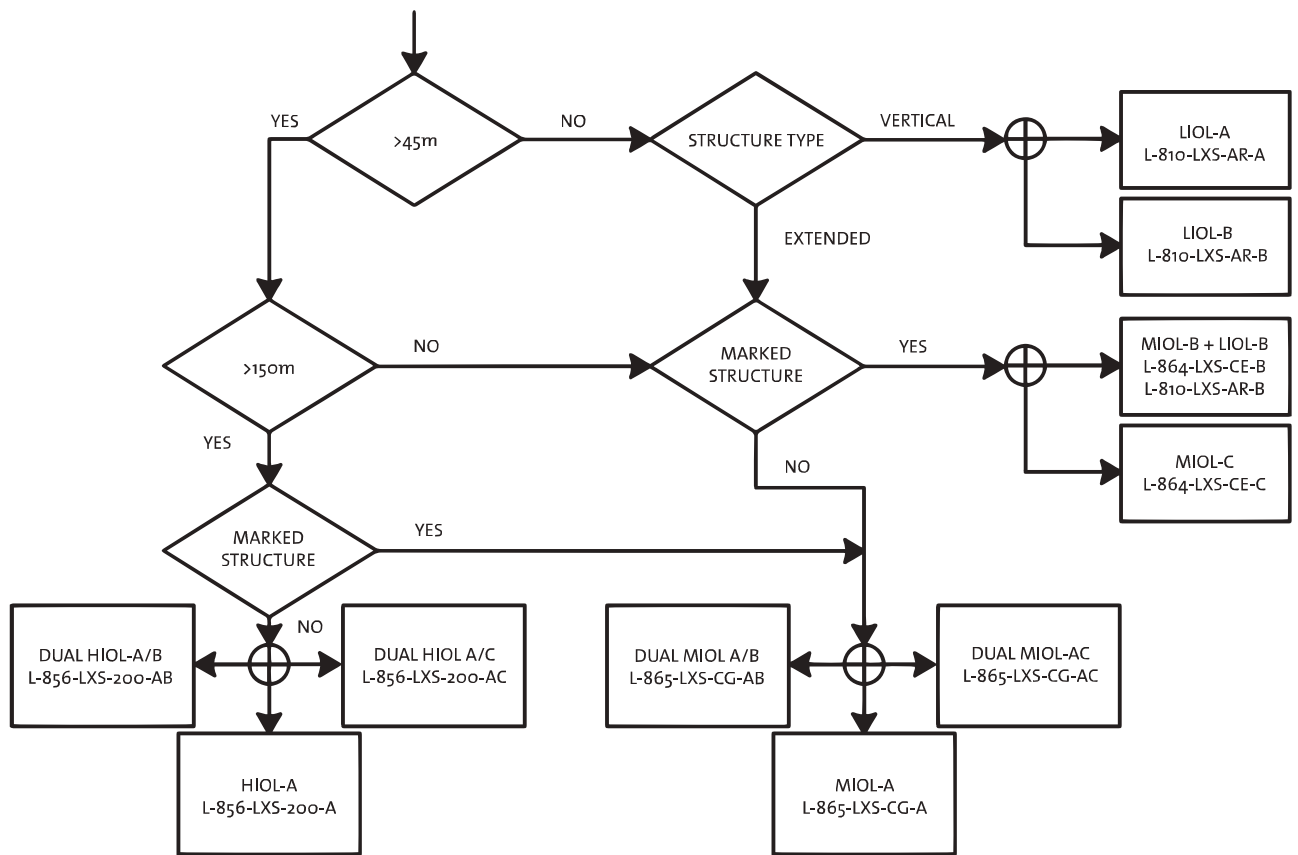

The number of lights required for each level depends on the external diameter of the structure being lit:
up to 6m = no. 3; from 6 to 30m = no. 4; from 30 to 60m = no.6; more than 60m = no.8.

Marked structure: structure painted in alternate sections of aviation orange and white paint.

Not marked structure: structure that is not painted in alternate sections of aviation orange and white paint.

Exteded structures: buildings horizontally extended within 3 km from airports.

Vertical structures: fixed obstacles above an horizontal surface.