

LIOL-A-Ex LIOL-B-Ex



LOW INTENSITY

Low intensity obstruction light multiled type, compliance to ICAO type A and B, FAA L-810 obstacle, night only.

- Based on LED technology
- Steady burning red light
- Long life time >10+ years expectancy
- Stabilized light output
- Weight: 3,7 kg
- Power consumption 4W
- ATEX: Extb IIIC T130°C Db IP66
- IECEx: ExtDA21 IP66 T130°C



Order code

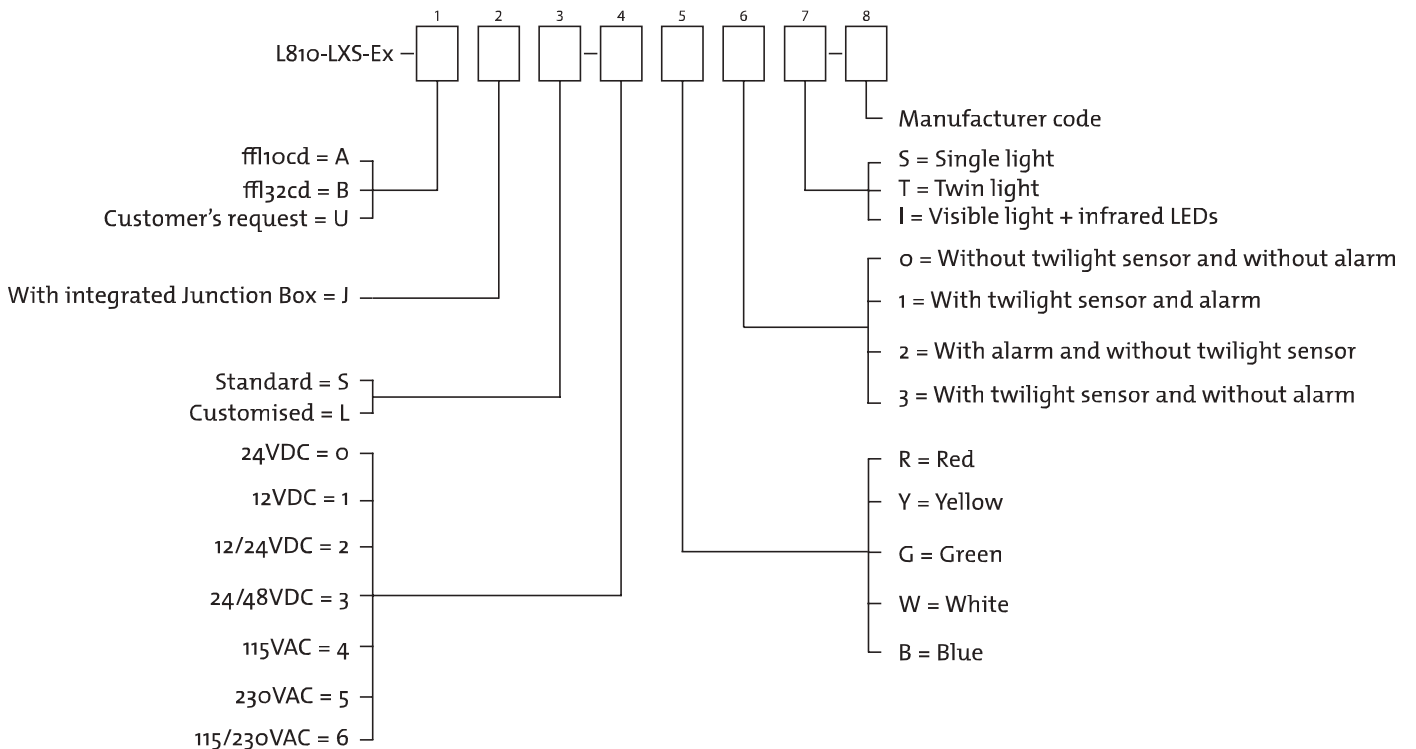

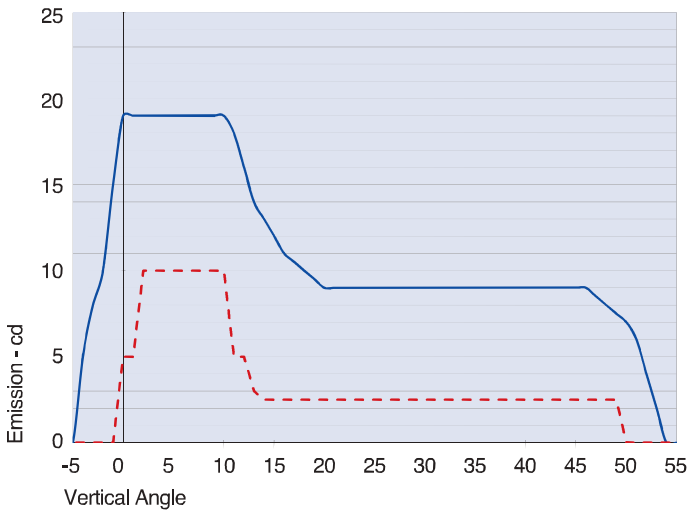

— L810-LXS-A average emission level
 - - - ICAO ANNEX 14 low intensity type A
 Minimum Required Intensity

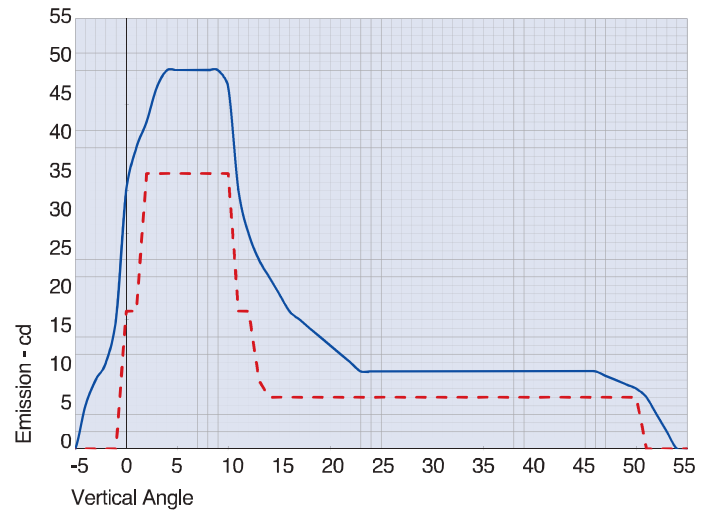

— L810-LXS-B average emission level
 - - - ICAO ANNEX 14 low intensity type B
 Minimum Required Intensity

FIG.1

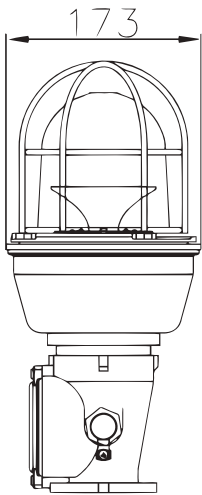

FIG.2

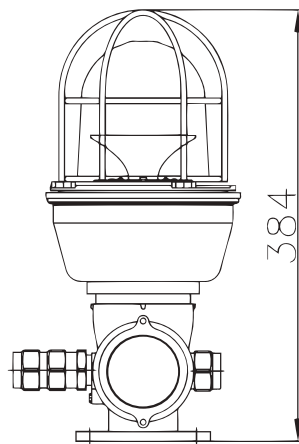

FIG.3

