	Scope : USER MANUAL TNAML Fluorescent luminaire Industrial				Date : 10-06-2016
	Rev. 6	Checked by : JG.	Approved by EG.	Page : 1 of 8	Procedure no. :

1. Marking:

	IP66	CE
TNAML 2x36 I		
S.No.		
U_n = 220-264 VAC 50/60 HZ		
T.amb. -20°C / +55°C		
TechNed Benelux	Spijk	NL

2. IMPORTANT: Emergency TNAML not installed

The batteries of emergency luminaires **MUST** be (re)charged when not installed (so in a stock) each 6 month after date of delivery to grant the correct life time of the batteries.

Procedure:

1. Unpack the luminaire.
2. Open the junction box.
3. Make the connection on the "B" terminal, see page 2 * **INSTALLATION OF EMERGENCY LUMINAIRE**, connect the luminaire to the normal power line, the fluorescent lamps will start functioning and the green LED will start flashing.
4. After 1 minute, disconnect the power line, the fluorescent lamps will stop functioning and the emergency LED's will start functioning.
5. Keep this situation till the LED's stop functioning. This takes up to 150 minutes. Now the batteries are fully discharged.
6. Re-connect the 230V power and the fluorescent lamps start functioning and the green LED starts flashing. Keep this situation for 24 hours. The batteries will be charged for approx. 95%(last 5% takes another 24 hours).
7. Disconnect the 230V power and disconnect the "B" terminal.
8. Close the junction box
9. Re-pack the luminaire
10. The emergency luminaire can be stored again for max. 6 months.

3. Installation:

Control that the luminaire is installed in an area with an ambient temperature (T.amb). within the temperatures that are mentioned on the label. If the temperature is out of these limits, the life time of the luminaire can be reduced.

Also verify the following:

1. Degree of protection (IP grade) of equipment is appropriate for the level of protection/group/conductivity. The TNAML luminaire is IP 66/68. IP 68 will occur only when the junction box is correctly filled, see procedure page 3.
2. Equipment circuit identification is available and correct
3. Enclosure and glass parts are undamaged
4. There is no evidence of unauthorized modifications

When installing the TNAML luminaire range, the correct current limitation is to be considered. This protection should be a fuse or a circuit breaker minimum 4kA with a C type characteristic.

	Scope : USER MANUAL TNAML Fluorescent luminaire Industrial				Date : 10-06-2016
	Rev. 6	Checked by : JG.	Approved by EG.	Page : 2 of 8	Procedure no. :

To define the quantity of luminaires per circuit, the table below can be considered.

Circuit breaker type	2x18/2x36 Watt	2 x 58 Watt
16A C	30 luminaires	20 luminaires

When earthleakage protection is installed, it should be version **30mA**.

4. Connections :

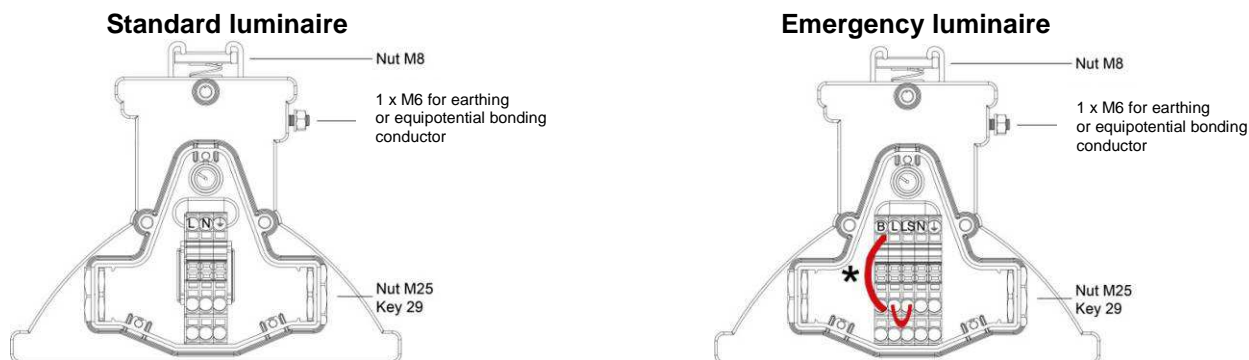

In the terminal box of the TNAML luminaires the terminal strip as shown above is installed.

Following connections can be made:

L-N Connection terminals for 230V AC powersupply, range 220-264V 50/60Hz
Earth connection terminal for internal earth wire.

For emergency version: (as standard L and LS is linked together)

LS – supply to the fluorescent light source (can be used to switch off this part)
L – supply to the emergency system

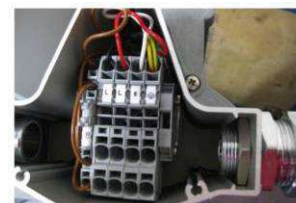

* INSTALLATION OF EMERGENCY LUMINAIRE:

Make wire connection on terminal B see drawing terminal box above for battery to be installed before sealing the terminal box (this will connect the precharged battery to the internal emergency circuit)

LED indication lamps of emergency luminaire:

The LED indication lamps are located at the edge of the glass on the opposite side of the terminal box. (whereas the white LED emergency lights are located at both edges of the glass).

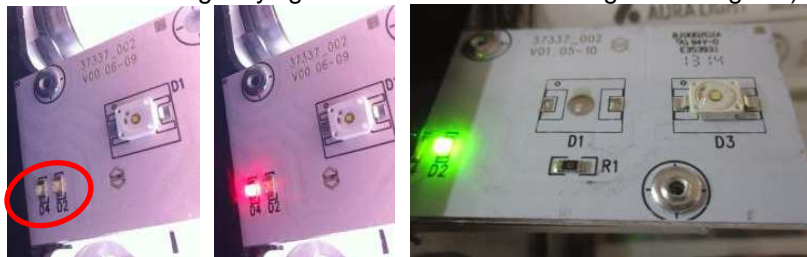

Green LED lights up continously:
Green LED is flashing:
Red LED is flashing:

battery is full or almost full (capacity between 95-100%).
battery is loading (capacity between 10-95%).
B-terminal is not connected (jumper connect is not installed)

	Scope :				Date :
	USER MANUAL TNAML Fluorescent luminaire Industrial				10-06-2016
Rev. 6	Checked by : JG.	Approved by EG.	Page : 3 of 8	Procedure no. :	

Option

Manned / unmanned system

The **Manned/Unmanned system** consist as a minimum of 1 control unit and 1 luminaire TNAML. The total system can consist of more control units and luminaires TNAML. The control unit consist of an electronic device that can send and receive codes to and from TNAML luminaires. Each TNAML luminaire has a slave type device to broadcast the signal.

The control unit **MUST** always be connected to a power circuit supplying 240V 50Hz via an UPS system. The control unit can be an industrial version or a version suitable for use in zones 1 /21and or 2/22.

The control unit has a switch **Manned/Unmanned** position with spring return

When the switch is switched to Manned, a green LED on the control unit will start to flash fast. The electronic device now sends during 30 seconds his code to the luminaires. After 30 seconds, the LED will function steady.

The TNAML luminaires are now in Manned condition. This means that when the power would fail, the emergency lighting system will operate.

The distance between the control unit and the first TNAML luminaire is max. 15 meters for use on a factory/ship. In free air , the distance is 50 meters. When the TNAML luminaires are installed at fire doors, there is to be installed a TNAML luminaire at each side of this door.

The TNAML luminaires that receive the code, transmit this code to the next luminaire and so on. There is a Christmas tree effect. In the unlikely situation that a TNAML luminaire would fail (mechanical damage) the transmitted code will always be send to the TNAML luminaires.

When the installation will be departed, so it becomes an **Unmanned** installation, the switch will be switched to unmanned. The red LED on the control unit will start flashing fast for 30 seconds. The electronic devise transmit a code to the TNAML luminaires. After 30 seconds the LED will operate steady. The TNAML luminaires are now in Unmanned situation. This means that when the power would fail, the emergency lighting system will NOT come in operation.

When returning to the site, the control unit will be switched to **Manned** and the emergency system will start to operate and depending the version of TNAML, there will be 90-180 minutes of lighting, granting a safe present on the site.

Installation:

1. Open terminal box by using a Torx type T25 screw driver.
2. Mount a nickel plated M25 cable gland, , complete with a nylon washer and counter nut inside the terminal box. Control if the cable diameter meets the sealing rings of the cable gland. Note that the gland is not with strain relief.
3. Strip the cable and wires for min. 11 and max.13 mm. Mount the wires through the cable gland and connect the wires to the terminals, max 6 sqmm flexible wires.
4. Connect the wires as shown earlier in the termination drawing (L, N and GND).
5. **On emergency version the battery need to be connected see first pictures of this chapter**
6. Close the cable gland according to the requirements instruction
7. Close the terminal box after check of functionality and Insulation resistance test, fill the terminal box with sealant material, included in packing.
1 cartridge = volume in terminal box



After making all connections and before filling the terminal box with sealant material, the following checks shall be carried out:

1. Bolts, cable entry devices and blanking elements are of the correct type and are complete and tight
2. Type of cable is appropriate
3. There is no obvious damage to cables
4. There is no evidence of ingress of water or dust in the terminal box in accordance with the IP rating
5. Electrical connections are tight
6. Earthing connections, including any supplementary earthing bonding connections are tight and conductors are of sufficient cross-section
7. Fault loop impedance (TN systems) or earthing resistance (IT systems) is satisfactory

	Scope : USER MANUAL TNAML Fluorescent luminaire Industrial				Date : 10-06-2016
	Rev. 6	Checked by : JG.	Approved by EG.	Page : 4 of 8	Procedure no. :

8. Automatic electrical protective devices such as MCB/MCCB are set correctly (auto-reset not possible)
9. Automatic electrical protective devices operate within permitted limits.
10. Equipment is adequately protected against corrosion, weather, vibration and other adverse factors No undue accumulation of dust and dirt on the luminaire
11. Electrical insulation is clean and dry

READ THE COMPLETE FILLING PROCEDURE MANUAL BELOW, or view (when possible and at safe location) on www.technedbenelux.nl the instruction video

Filling procedure for resin Ex e box (you will need a sealant applicator gun for a standard 310 ml cartridge)

1. The terminal box is closed
2. Install the tip onto the cartridge.
3. Cut the tip approx. 10 mm from the end.
4. Unscrew the M8 screw screw in the lid of terminal box.
5. Install the cartridge in the sealant applicator gun and inject the tip into the M8 hole of the the lid of terminal box.
6. Press the complete amount of resin into the M8 hole of the the lid of terminal box.
7. Pull occasionally the tip around 10mm back so possible air inside the terminal box can be released to the atmosphere.
8. *The terminal box is filled completely either when the whole cartridge is empty and then it is not possible to inject more material. (material will be forced back/out of the injection hole) All other methods of filling will not give a correct filling of the terminal box and consequently a reliable installation can not be granted. (Warranties will not apply in this case)*
9. Below some pictures what will happen inside the terminal box



10. After a successful filling, install and tighten up the M8 screw.

NOTE: The 10 year warranty is only valid if the terminal box is filled correctly with resin

5. Start up:

As soon as the power is switched on, the lamps will ignite within 2 seconds, the time can be influenced by the ambient temperature. **Never switch on the luminaire before all installation is completed and insulation test performed.**

6. Insulation resistance test:

In case of insulation resistance test, this can be done with test(Megger®) at 500VDC between line and earth or neutral and earth.

Never between line and neutral !!!!!!!!!!!

During production, the luminaire has had a dielectric test of 1800V for 1 second.

7. Dismantling

When removing the luminaire, the same precautions apply as those observed when mounting the luminaire.

	Scope :		USER MANUAL TNAML Fluorescent luminaire Industrial		Date : 10-06-2016
	Rev. 6	Checked by : JG.	Approved by EG.	Page : 5 of 8	Procedure no. :

8. Use:

The use of the luminaire does not require special conditions.

9. Inspection and Maintenance:

The luminaire is sealed for life and can not be openend for re-lamping etc..

1. Degree of protection (IP grade) of equipment is appropriate for the level of protection/group/conductivity
2. Equipment circuit identification is available
3. Enclosure and glass parts are undamaged
4. There is no evidence of unauthorized modifications
5. Bolts, cable entry devices and blanking elements are of the correct type and are complete and tight
6. Fluorescent lamps are not indicating EOL effects The luminiare is protected against EOL effects
7. There is no obvious damage to cables
8. Earthing connections, including any supplementary earthing bonding connections are tight and conductors are of sufficient cross-section
9. Equipment is adequately protected against corrosion, weather, vibration and other adverse factors, No undue accumulation of dust and dirt

	Scope : USER MANUAL TNAML Fluorescent luminaire Industrial				Date : 10-06-2016
	Rev. 6	Checked by : JG.	Approved by EG.	Page : 6 of 8	Procedure no. :

10. Warranty:

The luminaire has a 10 year operational warranty (see details in the warranty statement).

11. Standards

- IEN 60598-2-1:1989
- EN 55015:2006+A12007+A2:2009
- EN 61000-3-2:2006+A1:2009+A2:2009
- EN 61547:2009
- 61000-3-3:2008

12. Installation of the luminaire:

- Remove the luminaire from the carton packing.
- Control if the luminaire is mechanically damaged.
- Install the luminaire to the construction, see drawings / pictures below.

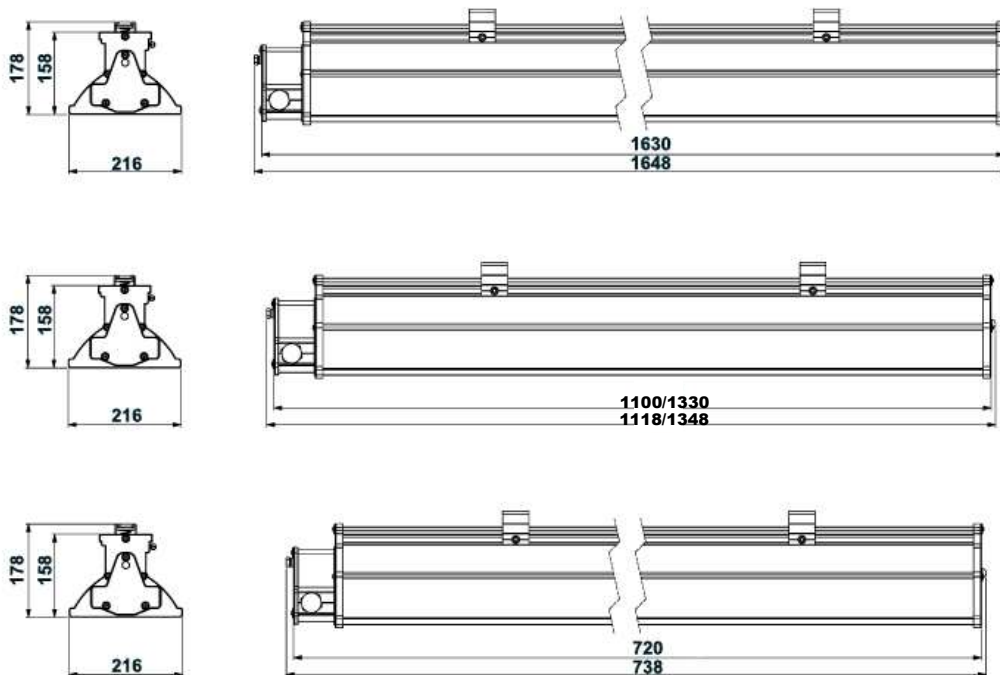

Ceiling mounting:

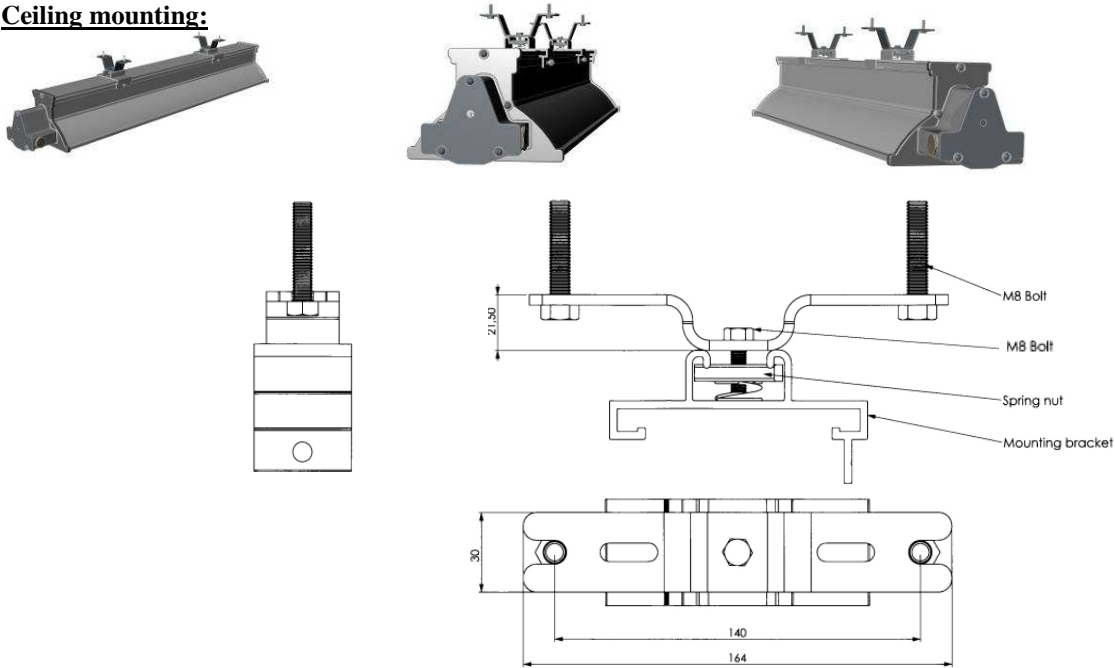

Pole mounting:

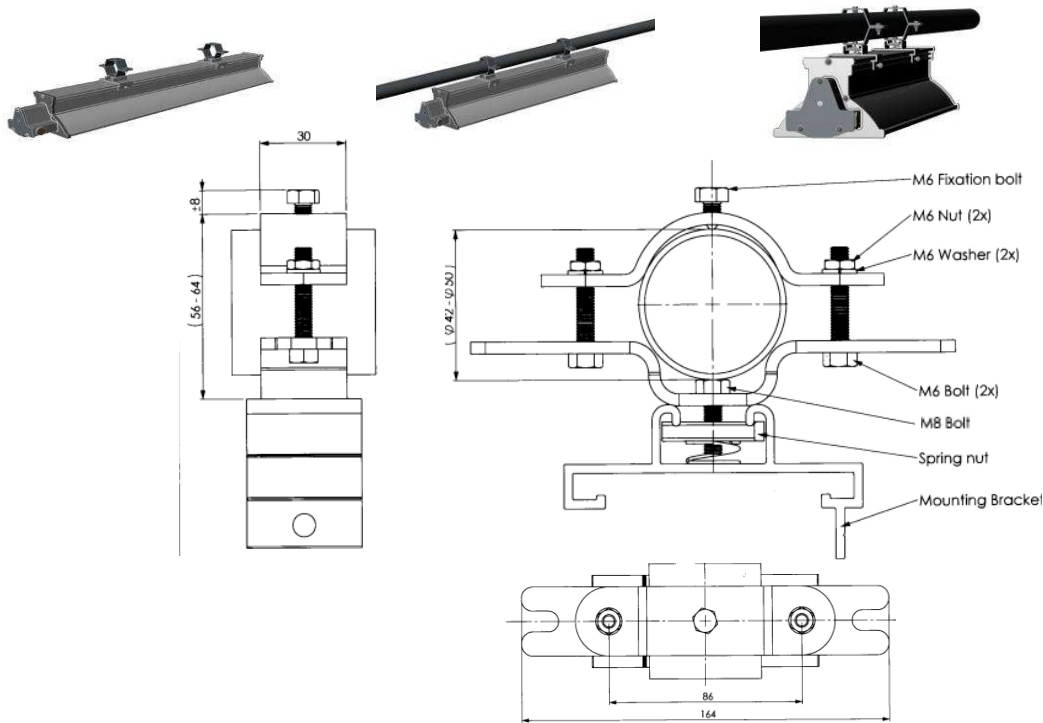

Pendant mounting:



Mounting on steel plate of ship:

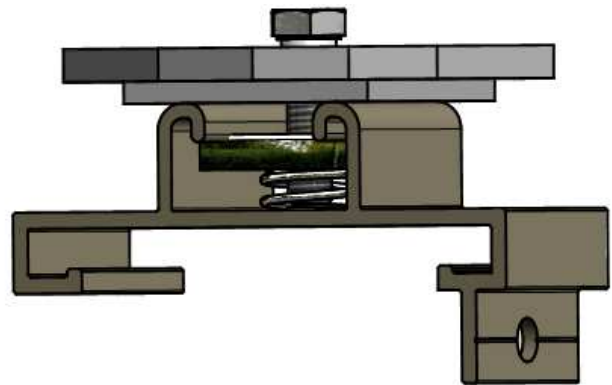
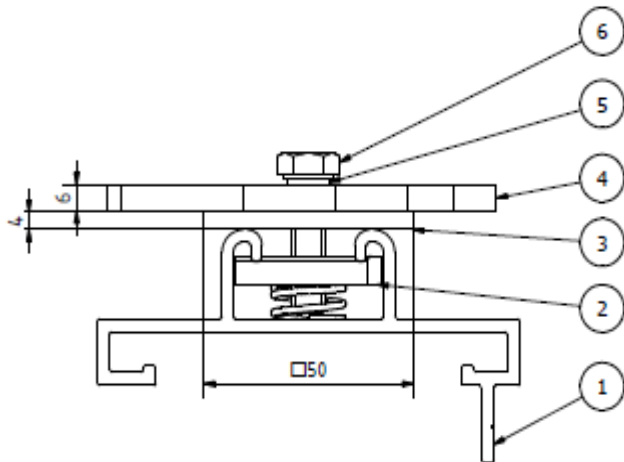

1. Suspension profile (part of the luminaire)
2. Sliding/spring nut
3. Plate Korrex or HPME
4. Steel plate of ship
5. Ring Duba M8
6. Bolt M8 x 30

The spring nut (component part 2 on the drawing) which is delivered with the luminaire (attached on the luminaire as delivered) has to be removed and replaced by the spring nut which is delivered as part of the mounting on steel plate of ship set.

	Scope : USER MANUAL TNAML Fluorescent luminaire Industrial				Date : 10-06-2016
	Rev. 6	Checked by : JG.	Approved by EG.	Page : 9 of 8	Procedure no. :



EU- Declaration of Conformity:

Equipment: **Luminaires Series TNAML I and Series TNAML-E I**
 Manufacturer: **TechNed Benelux bv**
 Address: **Veersteeg 15, 4212 LR Spijk, Netherlands.**

TechNed Benelux bv declares that the equipment is in compliance with the applicable requirements in de following European Directives:
 LV Directive 2014/35/EU, EMC Directive 2014/30/EU, REACH Directive 2006/121/EC and ROHS Directive 2011/65/EU (Only for TNAML-E)

The following harmonised standard have been applied to comply with the applicable requirements in LV Directive 2014/35/EU:
EN 60598-1:2008+A11:2009, EN 60598-2-1:1989,

The following harmonised standard have been applied to comply with the applicable requirements in EMC Directive 2014/30/EU:
EN 55015:2006+A1:2007+A2:2009, EN 61000-3-2:2006+A1:2009+A2:2009,
EN 61000-3-3:2008, EN 61547:2009

Spijk, 10-06-2016

 QA Manager